



ARJES

Recycling Innovation

THE ULTIMATE PRIMARY SHREDDERS

WITH THE BEST PRICE-PERFORMANCE RATIO



INNOVATION IS WHAT KEEPS US THRIVING!

ALWAYS IN THE SPOTLIGHT – MOST EFFECTIVE CUSTOMER BENEFIT!

The company ARJES, well known for their double-shaft shredding machines, is one of the world's leading suppliers of exceptional shredder with extremely high mobility way ahead of its competition. Combined with the spirit of innovation, radiated by all our employees, our products are flagships for strong and steady growth as well as economic success.

Since the company was founded in 2007 approximately 200 employees have been producing trend-setting solutions for the processing of green waste, stem and waste wood, plastics and industrial waste, scrap metal as well as construction waste and minerals on the grounds of the company in Leimbach, Thuringia.



THE RIGHT SHAFT SYSTEM FOR EVERY APPLICATION!

Due to the close relationships we maintain with our customers as well as the evaluation of test and product operations we are able to rely on comprehensive experience. Therefore, we are capable to offer the ideal solution according to your individual requirements.

The slow-speed two-shaft system forms the basis for all applications of pre-shredding. Depending on the material, however, it may be necessary to adapt the configuration in terms of geometry (hooks, paddles, plates, knives) and arrangement in order to achieve the best possible result.

In combination with a synchronous / asynchronous drive, materials such as concrete, construction waste, asphalt, car bodies, light metal, engines, waste wood, trunk wood, roots, wooden sleepers, refuse, mattresses, carpets, tyres and much more can be shredded and processed without any problems.



Example for our shafts



SERVICE AND SPARE PARTS

Periodical service and maintenance intervals ensure that our machines and plants live longer and work efficiently. We are there whenever you need quick help!

- ✓ Support during commissioning and training by qualified personnel
- ✓ Engine and hydraulics service by qualified service technicians
- ✓ Technical support and damage assessment via service hotline
- ✓ Preparation of tool shafts, painting work and complete machine regeneration
- ✓ Fast worldwide delivery of spare and wear parts
- ✓ Test run and fine tuning





GREEN WASTE, STEM AND WASTE WOOD

Felled, delimbed and polled trees are also known as green waste and stem wood. Waste wood, on the other hand, has already been used for a different purpose and, therefore, may contain iron and metal parts. Our shafts are just slightly affected by those substances and are particularly resistant during the shredding process. These materials are used for heat and power generation, but also as building materials and raw materials in the paper industry.

Our strengths in this area:

- Branchwork and garden waste
- Rootstocks
- Demolition wood
- Pallets and cable drums
- Railway sleepers



PLASTICS AND INDUSTRIAL WASTE

Waste produced by businesses and private households contains many different types of material such as plastic, wood, paper, cardboard, glass or metal. In addition to ideal shredding, effective separation of metal-containing materials is of particular interest. Due to the high calorific values and the low compostable content this material can be processed for the recovery of substitute fuels.

Our strengths in this area:

- Domestic and industrial waste
- Tyres
- Mattresses and carpets
- Plastics and Big Packs
- Paper and cardboard



FIELDS OF APPLICATION WITH HIGHEST REQUIREMENTS



SCRAP METAL

Products that contain metal and which are produced during the scrapping of car wrecks are mainly used as secondary raw materials. Very resistant shredding tools are required to reduce the volume. An automatic reversing function also protects the knives against fractures. FE and non-ferrous metals are valuable resources for the recycling process in steelworks and foundries.

Our strengths in this area:

- Car bodies*
- Engine blocks
- Aluminium rims and profiles*
- White goods
- Household and mixed scrap*

* up to a maximum of 3 mm (mobile) / 5 millimeters (stationary) material thickness



CONSTRUCTION WASTE AND MINERALS

Large quantities of construction waste are produced on construction sites during the construction of new buildings, expansion and demolition. The term refers to mineral waste and building materials such as concrete, asphalt, bricks and mortar residues. These must be considerably reduced in volume before they can be further processed into recycled concrete or as fillers for road and path construction.

Our strengths in this area:

- Mixed construction waste
- Asphalt and concrete
- Ceramics and tiles
- Roof tiles
- Cinder



IMPAKTOR 250 EVO THE NEXT EVOLUTION

Following continuous and steady development ARJES is going to present the next evolutionary step – the IMPAKTOR 250 EVO. In addition to a worldwide unique combination of track mobility and a hook lift version, the „EVO“ model features a revolutionary quick-change shaft system, a new and even more innovative control system as well as a new shaft design that expands the range of applications of the shredder many times over.



DISCHARGE BELT

Conveyor belt for efficient material discharge up to 3,400 mm height



MAGNET

Principal feature!
Strong permanent magnet for effective FE separation



SHREDDING UNIT

Large-volume hopper and shaft system with **quick-change cassette**



CONTROL SYSTEM

Predefined shredding profiles for adjusting the shafts incl. **remote control**



TRACK SYSTEM

Principal feature!
Guaranteed high mobility on uneven surface

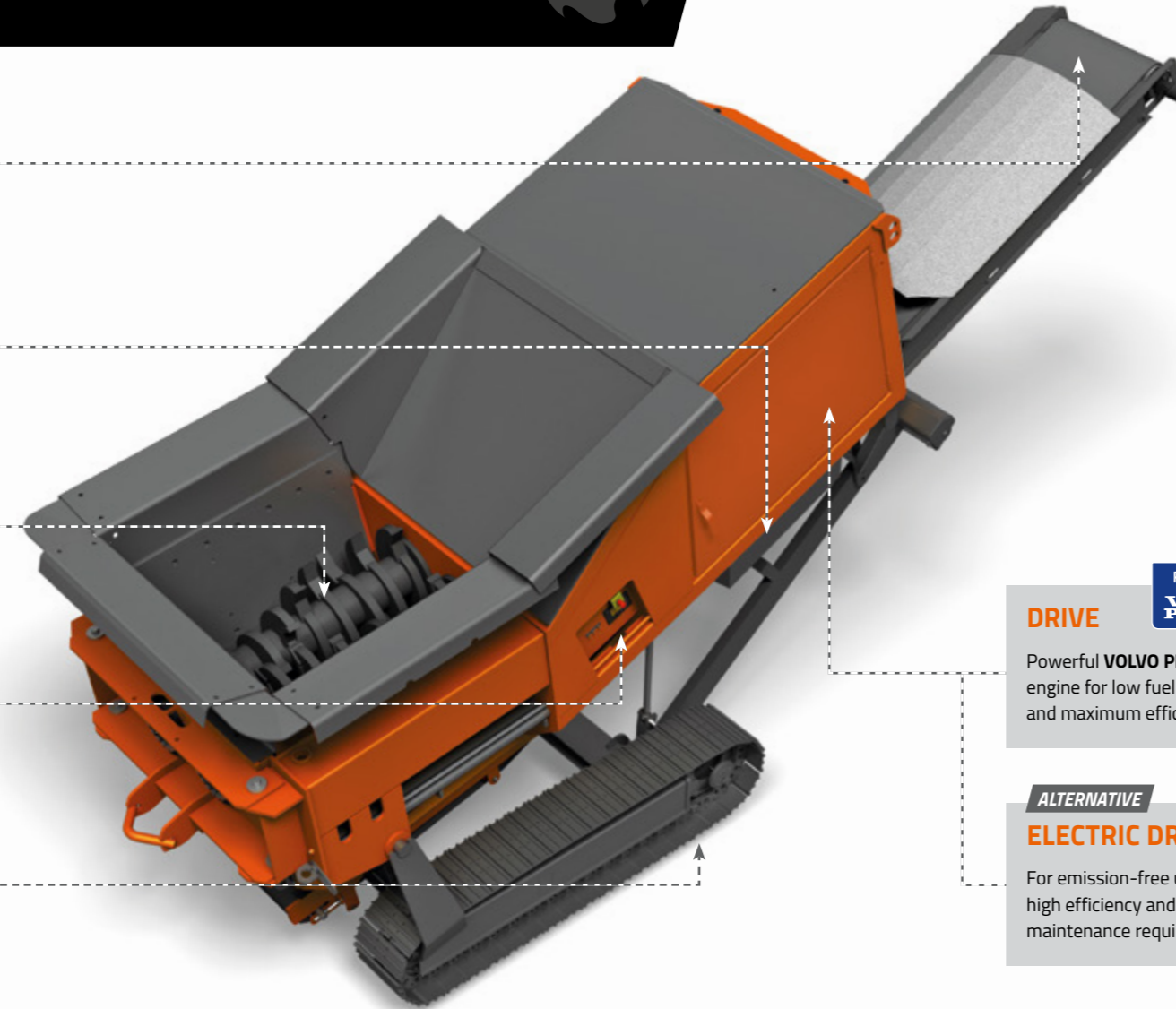

DRIVE

Powerful **VOLVO PENTA** diesel engine for low fuel consumption and maximum efficiency



ALTERNATIVE

ELECTRIC DRIVE

For emission-free use with high efficiency and minimum maintenance requirements



DIMENSIONS

Version	Track system
Length (mm)	6.700 / 7.500 (Transport)
Width (mm)	2.300 / 2.300 (Transport)
Height (mm)	3.500 / 2.800 (Transport)
Total weight (kg)	13.500

DRIVE

	EU	US	ROW*
Engine (Volvo Penta)	TAD 571 VE	TAD 572 VE	TAD 552 VE
Emission standard	EU Stage IV	EPA Tier 4f	Stage 3A
Power (kW / HP)	129 / 175	160 / 220	160 / 220
Fuel capacity (l)	360		
Gearbox (Nm)	Bonfiglioli 160.000		

DISCHARGE BELT

Discharge height (mm)	3.400
Width (mm)	800
Included	Over-belt magnet

SHREDDING UNIT

Hopper volume (m³)	2,25
Shaft length (mm)	1.500
Shaft diameter (mm)	680
Weight (kg / cassette)	3.800
Rotation speed (rpm)	11 – 45



Easy transport to any place of work

Due to the low basic weight and a hydraulically lowerable chassis, the transport on a small trailer is possible without special permission or also by hook lift truck.

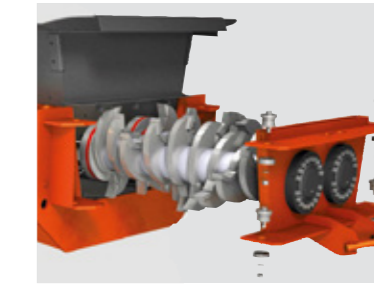

Quick change system for tool shafts

Easy installation and removal of the shaft pair within the shortest time, facilitates maintenance, preparation and changing of the shaft type for uninterrupted operation.



Mechanically adjustable side combs

The side combs can be completely opened or closed to regulate the final output. Depending on the material and the customer's requirements, the throughput capacity is thus determined.



FIELDS OF APPLICATION





5 CONVINCING ARGUMENTS

- 1 **Best price-performance ratio in its class**
incl. extended warranty and cost-optimized wear packages
- 2 **Largest range of applications**
processing of minerals, garbage, waste wood, tyres, mattresses and much more
- 3 **Revolutionary shaft quick-change system**
flexible uninterrupted use in any material
- 4 **Maximum mobility in every situation**
track system as standard and transport by hook lift
- 5 **Innovative user-friendly control**
Predefined shredding profiles for adjusting the shaft speed

IMPAKTOR 250 EVO



**RELIABLE
POWERFUL
COMPACT**

VZ 950 TITAN THE POWERFUL & PROFESSIONAL SHREDDER

In nature, the element TITAN is a symbol for stability, reliability and durability with comparatively low weight. These characteristics were the decisive specifications for the development of the new machine generation. In order to guarantee the widest possible range of applications with the best results we are offering a new variant for processing waste, waste wood, green waste and minerals in addition to the further developed option for metal shredding.



REVERSING FAN

Ideal air circulation for max. performance and dust reduction in the engine compartment



MAGNET

Principal feature! Strong permanent magnet for effective FE separation



SHREDDING UNIT

Large-volume hopper and shaft system with **quick-change cassette**



CONTROL SYSTEM

Predefined shredding profiles for adjusting the shafts incl. **remote control**



TRACK SYSTEM

Principal feature! Guaranteed high mobility on uneven surface

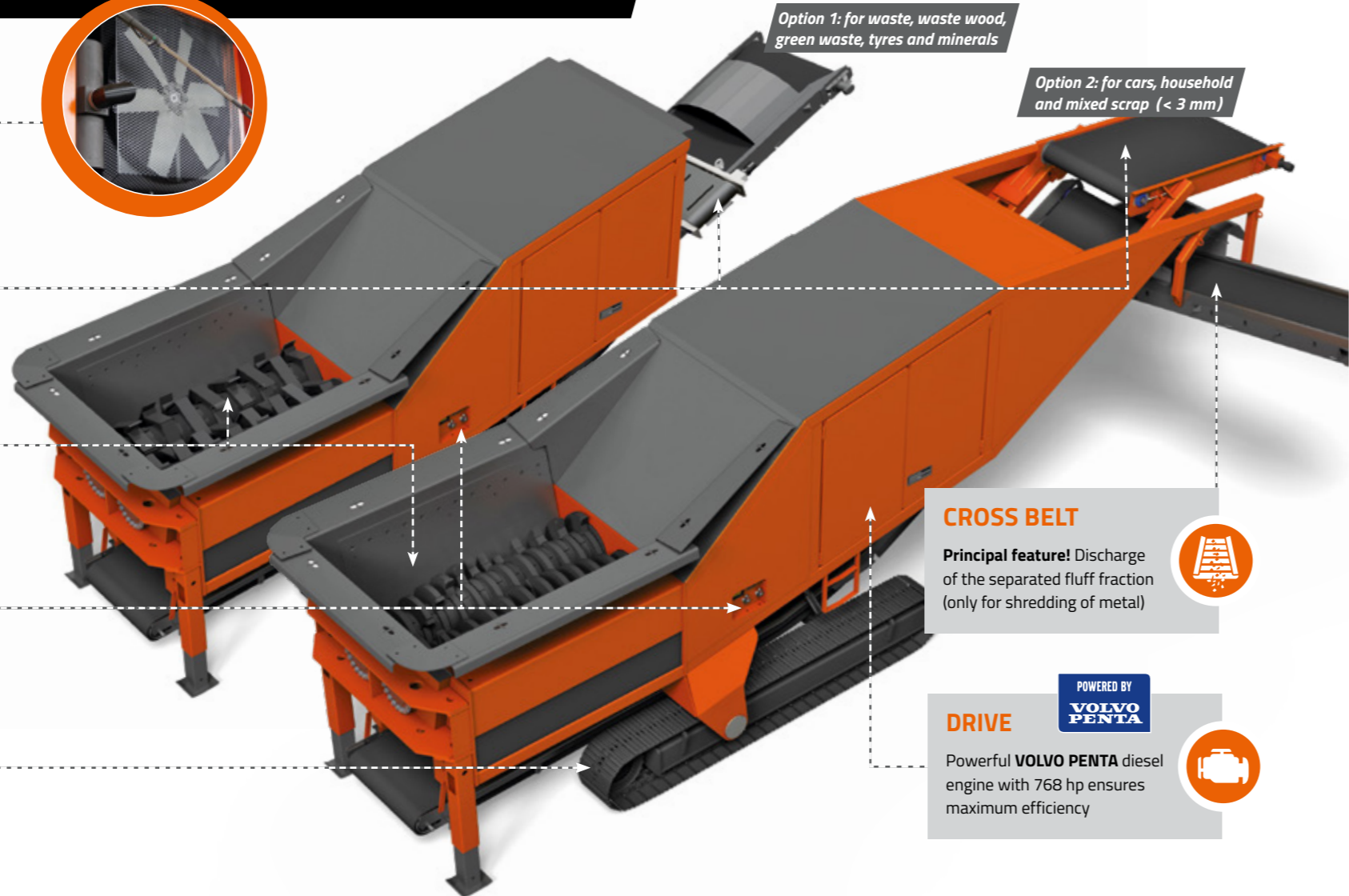

Option 1: for waste, waste wood, green waste, tyres and minerals

Option 2: for cars, household and mixed scrap (< 3 mm)

CROSS BELT

Principal feature! Discharge of the separated fluff fraction (only for shredding of metal)



DRIVE

Powerful **VOLVO PENTA** diesel engine with 768 hp ensures maximum efficiency



DIMENSIONS

Version	Track system
Length (mm)	10.800 / 11.500 (Transport)
Width (mm)	3.000 / 3.000 (Transport)
Height (mm)	4.300 / 3.600 (Transport)
Total weight (kg)	36.000 / 39.000 (Metal-Version)

DRIVE

	EU	US	ROW*
Engine (Volvo Penta)	TAD 1643 VE	TAD 1672 VE	TAD 1643 VE
Emission standard	EU Stage II	EPA Tier 4f	EU Stage II
Power (kW / HP)	565 / 768	515 / 700	565 / 768
Fuel capacity (l)	800		
Gearbox (Nm)	Bonfiglioli 500.000		

DISCHARGE BELT

Discharge height (mm)	max. 4.000
Width (mm)	1.200
Option 1 (Included)	height adjustable over-belt magnet
Option 2 (Included)	cross belt and length magnet

SHREDDING UNIT

Hopper volume (m³)	5
Shaft length (mm)	2.500
Shaft diameter (mm)	950
Weight (kg / cassette)	7.000
Rotation speed (rpm)	15 – 45

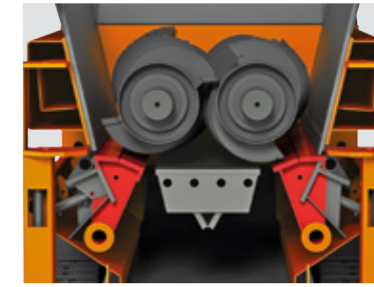
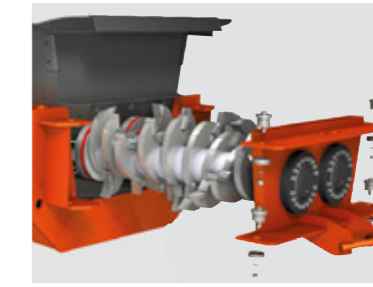

Great mobility and transportability

The track system as standard ensures ideal mobility on site and makes transport via a low loader even more cost-effective and efficient at the same time.

Quick change system for tool shafts

Easy installation and removal of the shaft pair within the shortest time, facilitates maintenance, preparation and changing of the shaft type for uninterrupted operation.

Automatically pressure controlled damping system**

If the resistance is too high the side combs, marked in red, are hydraulically folded in and out. That procedure prevents damage to the shredding unit and regulates the size of the shredded material.

** for Metal-Version



FIELDS OF APPLICATION





POWERFUL
ECONOMICAL
FLEXIBLE

VZ 950 TITAN



5 CONVINCING ARGUMENTS

- 1 Best price-performance ratio in its class**
incl. cost-optimized wear packages
- 2 Largest range of applications**
Processing of car bodies, scrap, waste, wood, minerals and much more
- 3 Revolutionary shaft quick-change system**
flexible and uninterrupted use in any material
- 4 Maximum mobility in every situation**
track system as standard and cost effective transport
- 5 Innovative user-friendly control**
Predefined shredding profiles for adjusting the shaft speed

VZ 950 TITAN E-PU THE STATIONARY POWER PACKAGE

For every situation in which special requirements for exhaust and noise emissions apply, a power unit is the right choice. The shredder is divided into individual components in order to comply with structural requirements. This allows it to be easily integrated into recycling plants or used as a single machine. The ideal shredder for all applications where there is no need for mobility but for maximum efficiency with minimum maintenance.



See the VZ 950 TITAN E-PU live in action!

SHREDDING UNIT

Large-volume hopper and shaft system with **quick-change cassette**



CONTROL SYSTEM

Siemens SPS control possible for flexible integration according to customers requirements



STATIONARY

Integration in recycling plants possible due to separate machine components



ELECTRIC DRIVE

Electro Power-Unit that impresses with high efficiency and low energy costs

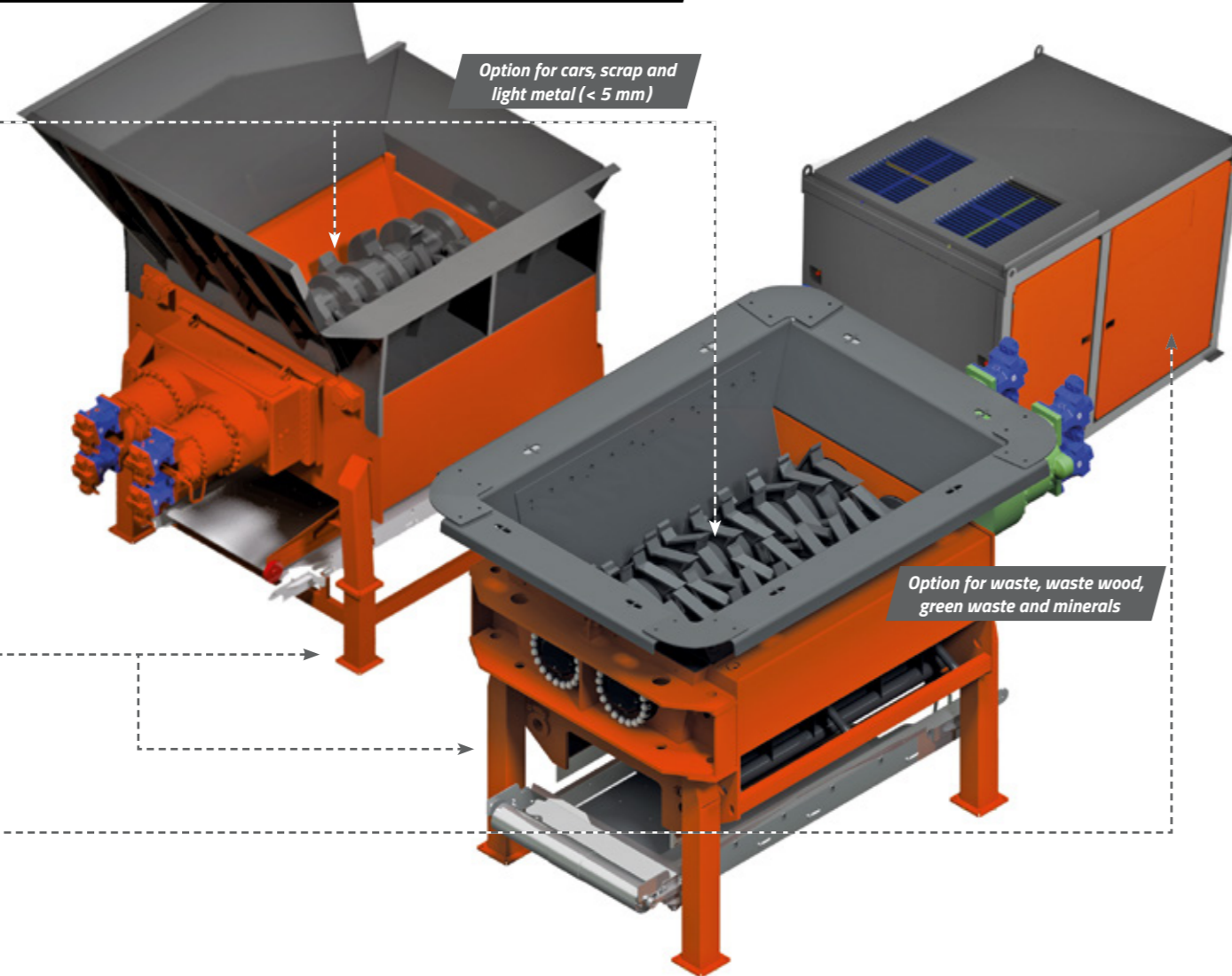

DIMENSIONS

Version	Stationary
Length shredding unit (mm)	5.000
Width shredding unit (mm)	3.000
Height shredding unit (mm)	3.100
Length E-PU (mm)	3.200
Width E-PU (mm)	2.300
Height E-PU (mm)	2.300
Total weight (kg)	30.000

DRIVE

Engine	Electro Power Unit
Power (kW)	2 x 250
Gearbox (Nm)	Bonfiglioli 500.000

SHREDDING UNIT

Hopper volume (m³)	5
Shaft length (mm)	2.500
Shaft diameter (mm)	950
Weight (kg / cassette)	7.300
Rotation speed (rpm)	15 – 45



Separate control unit (E-PU)

Due to the separate placement up to a maximum distance of 10 meters, significantly less vibration is affecting the control system. Additionally dust and dirt are reduced.

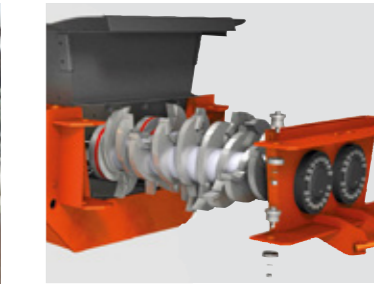

Quick change system for tool shafts

Easy installation and removal of the shaft pair within the shortest time, facilitates maintenance, preparation and changing of the shaft type for uninterrupted operation.



Special version for metal shredding

For particularly rough and heavy metal parts, the suspension of the hydraulically damped side combs is located above the shafts, which are automatically folded out if the resistance is too high.



FIELDS OF APPLICATION





LOW MAINTENANCE
ENERGY SAVING
EFFICIENT

VZ 950 TITAN E-PU

5 CONVINCING ARGUMENTS

- 1** **Best price-performance ratio in its class**
incl. cost-optimized wear packages
- 2** **Largest range of applications**
Processing of metal, waste wood, industrial waste and much more
- 3** **Revolutionary shaft quick-change system**
flexible and uninterrupted use in any material
- 4** **Highest efficiency**
for the most difficult materials with the lowest energy costs
- 5** **Minimal maintenance effort**
Sturdy and resistant to interfering substances





ARJES

Recycling Innovation

ARJES GmbH

Werksplatz 1 | D-36433 Leimbach

☎ +49 (3695) 85 855-0

☎ +49 (3695) 85 855-14

✉ info@arjes.de

🌐 www.arjes.de



Your local dealer