

ELDAN Fine Granulators

Up to 4500 kg/h



FINE GRANULATORS

The ELDAN Fine Granulators are high speed, single shaft granulators for the final granulation step. The Fine Granulators are specially designed for processing materials like tyres, cables, aluminium scrap (all types), plastics, etc.

- Adjustable knife clearance for optimizing the cutting function
- The knives can be reground multiple times on a “flat-bed” grinder ensuring long life and low operation costs
- The design of the machine ensures quick and easy change of knives
- Hydraulically operated inlet hopper provides easy access to the cutting chamber for maintenance
- Exchangeable wear parts give you a virtually indestructible machine
- Screens with different hole sizes available to ensure a more flexible production



Fine Granulators

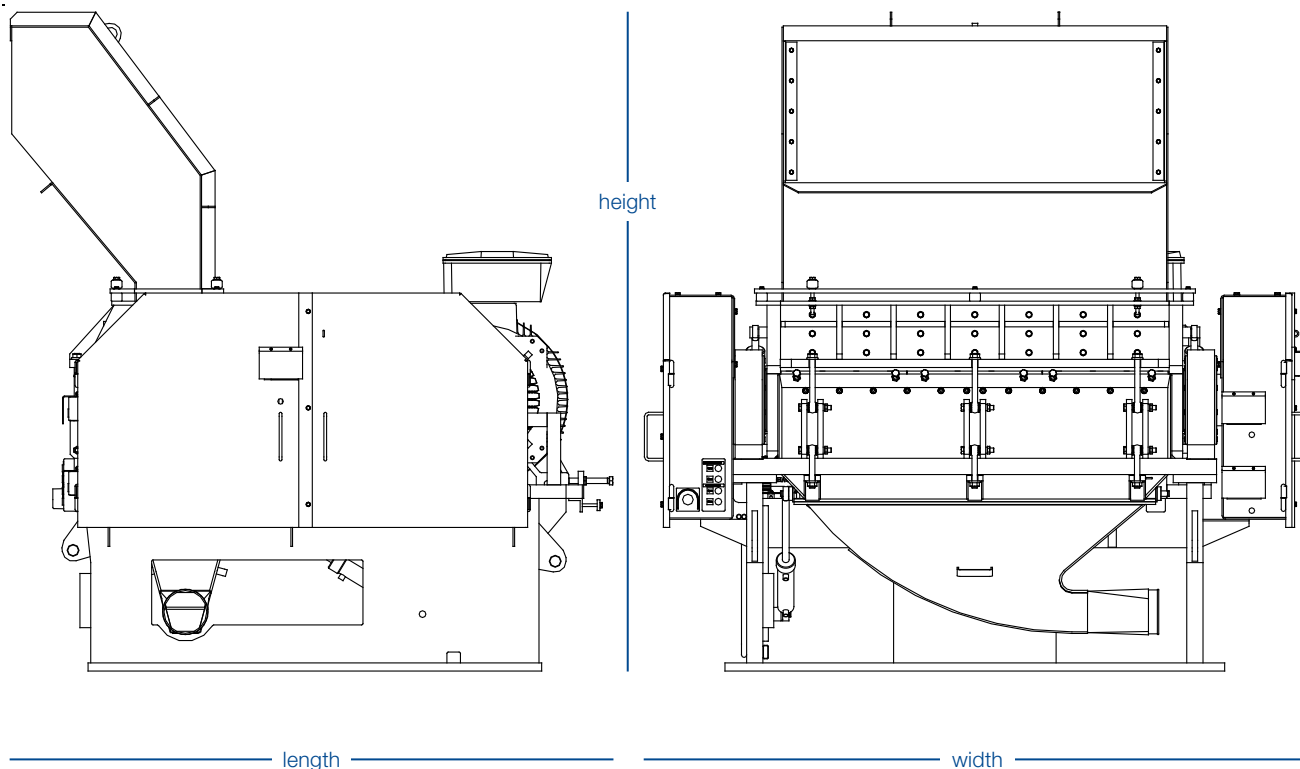

Technical specifications	FG476	FG952	FG1504	Units (EN / US)
Rotor length	475 / 19	950 / 38	1425 / 57	mm / in
Rotor speed	475	475	460	rpm
Knives - flying	6	12	18	pcs
Knives - static	2	4	6	pcs
Capacity *	Up to 2000 / 4400	Up to 3500 / 7700	Up to 4500 / 9900	kg/lbs per production hour
Motor	45	75	110	kW
Motor speed	1480	1480	1480	rpm
Weight (approx.)	3400 / 7480	4400 / 9680	7750 / 17050	kg / lbs
Dimensions	1900 / 76	1940 / 77,6	2100 / 84	mm / in
Width	1250 / 50	1960 / 78,4	2500 / 100	mm / in
Height	2800 / 112	2800 / 112	2900 / 116	mm / in

* Depending on type of input material, method of feeding and screen size
 Standard voltage: 3 ph, 400 V, 50 Hz – for other voltages please contact our sales department

