

TEREX 2/3 FRACTION
DRUM SCREEN

TTS 520 / TTS 520-3



We turn **visions** into ...

UNIQUE TECHNOLOGY

EASY HANDLING

PROFITABILITY

PERFORMANCE

QUALITY

ASDA

ADDED VALUE

COMPACTNESS

MINIMAL FUEL
CONSUMPTION

MAINTAINABILITY

VERSATILITY

UNCOMPROMISINGNESS



... **groundbreaking new technologies**

TTS 520 – one drum... 2 fractions



The TTS 520 is an all-purpose drum screen with an innovative Load Sensing System for minimum fuel consumption.

The extremely solid design has enough resources to even process heaviest materials like gravel and soil. The chassis, which is certified up to 80 km/h, is also perfectly suitable for nationwide utilization.

Open access to the motor, the hydraulic system and the drum considerably facilitates maintenance, cleaning and drum change.

With optional extension walls the capacity of the filling bunker is enhanced by 20% the hydraulic front drive of the feeding belt is ensuring the transportation into the drum. A slip through of the conveyor is therefore impossible, even with very heavy material. During the filling of the conveyor the TTS 520-3 can be equipped with an over length separator; we optionally offer a stone grate or a vibro grate.

4WD for the drum screen, this concept doesn't only considerably reduce abrasion and maintenance effort, it also enables drum change in record time and without tools.

In order to do so the side cladding and the brush are opened by a hydraulic system and the drum can be changed. The drum is serially equipped with an overload protective device.

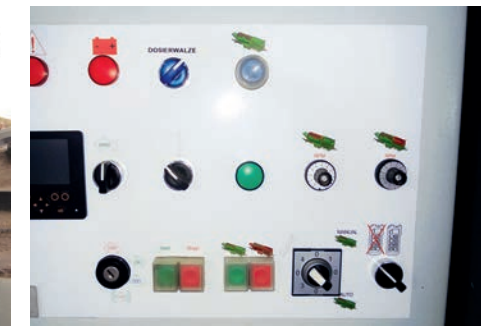

No auger in the drum, no forced conveying – in order to guarantee an optimum output quality with varied materials, the drum tilt, as well as all of the drivetrains are individually adjustable.

Drums are available in different sizes, in steel and hardox, as well as with a new and innovative mesh grid-quick-change system. Existing Terex Environmental Equipment drums are of course compatible. Especially for the processing of domestic waste an innovative Bag-Opener-System is offered.

Hence nothing falls beside the conveyor – the new, one-piece fine-grain conveyor ensures that no material can accumulate underneath the machine.

With an electric hydraulic pump all hydraulic drives can be operated even without the main engine. The feed bunker is equipped with a drum-sided drive (hydraulic front drive), to take advantage of a drum conveyor belt and easiest maintenance.

Full variability with as little buttons as possible. With our intuitive control panel the speed of the drum and the conveyors can be adapted perfectly to the various materials.

The drivetrains can thereby be controlled independently. A remote control is optionally available. Alternatively to the diesel engine there is also an electro engine available.

TTS 520-3 - one drum... 3 fractions



The TTS 520-3 poses a completely new and considerably cheaper alternative to the star screen.

The patented system based on the TTS 520 and enables separation in 3 fractions with all the advantages of a drum screen – low-maintenance, higher screening quality and easy setup. In transport position the dimensions equal the 2-fraction-version and therefore guarantees maximum mobility and flexibility.

The additional disc screen system enables the separation of a third fraction and combines top-performance with maximum flexibility.

Therefore there is the possibility, among others, to bypass the disc deck with an extra operational mode and to screen 2 fractions without abrasion of the disc deck. With the TTS 520-3 as well, all of the drive train parameters are individually adjustable.

It doesn't matter if you are feeding with a wheel loader or a conveyor, if you are processing biomass, compost, gravel or waste, with the TTS 520 you have the suitable tool to extract more revenue out of every m³.

During the development of our machines quality, profitability and uncompromising flexibility always have priority.



Core part of our 3-fraction-systems is the disc screen. The metal discs are not only considerably more resistant to abrasion, they can also be exchanged individually to keep the costs low.

In addition to that, due to the flexible design, a grain size from G50 to G200 can be reached depending on the used disc size and distance element which can also be subsequently adapted at any time.

With this screen generation, the discharging belts have been revised consistently. This has not only enhanced the material flow, but it has also been put focus on the protection of the hydraulic cylinders.

The discharge height of the sideband, as well as the height of the side panels of the conveyor belts have been enhanced.

We use only high-end components. No matter if engine, hydraulic systems, steel construction and electronics, quality is absolutely worth it in the long run and is positively reflected in the life cycle of machine.

The maintenance-friendly design and a well thought-through concept ensure, that the machine can productively operate over a long period.

Load Sensing as standard:
Both TTS 520 versions are equipped as standard with an economical Load-Sensing-Hydraulic-System.

OPTIONS

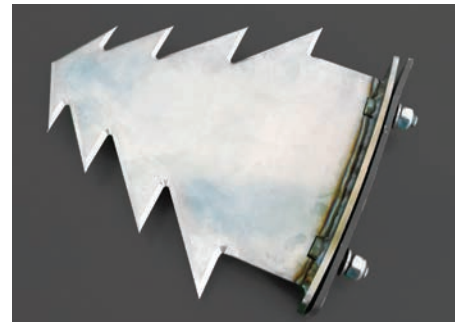

The TTS 520 can additionally be equipped with a stone grate or a vibro grate to remove large debris out of the sieving.

The over length separator based on a disc deck is posing another option.

The Terex Environmental Equipment Bag-Opener-System for utilization in the waste management Industry.

With this system it is for the first time possible to open and screen the content of a bin bag in one individual step. You can reach, depending on the number of used knives, a success rate of up to 90%. The system can also be installed subsequently.

The side conveyor as well as the rear conveyor are offered in two different lengths and are available in 3,500 mm and 5,000 mm.



Drums are available with 10x10 mm to 50x50 mm screen mesh, as well as 10x10 mm to 100x100 mm steel and hardox boss.

A quick-change system is available for drums with screen mesh which facilitates the use of different size mesh grids with only one drum - special sizes upon demand.

Existing Terex Environmental Equipment drum series TS 5220 can of course be used with the TTS 520.

With the radio remote control following functions can be operated:

- » diesel engine speed +/-
- » tilt +/-
- » crawler gear
- » engine stop
- » automatic on/off
- » filling conveyor backwards

Numerous other options can be ordered for example

- » central lubrication system
- » fire extinguishing equipment
- » working headlight
- » magnet roller incl. aluminum slide
- » special finish
- » and many more

This overview is of course not comprehensive, but we are certainly satisfying all of our customer's needs if they are within our technical feasibilities.

TTS 520

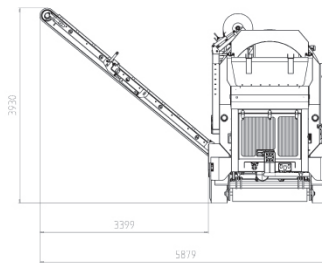
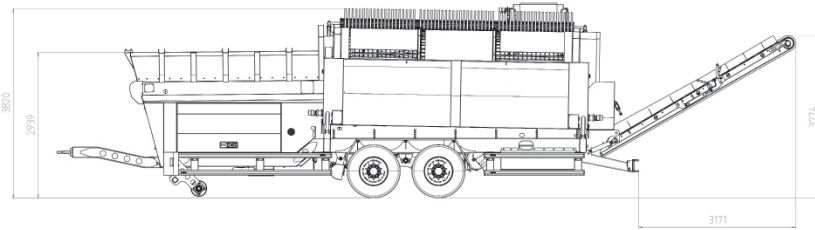
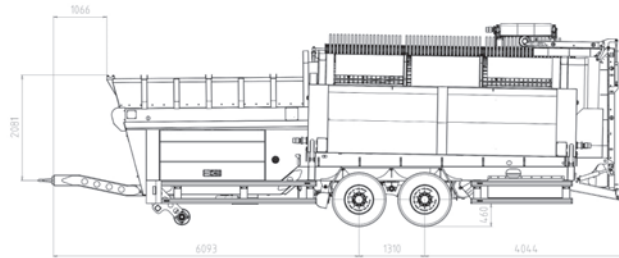

TTS 520-3

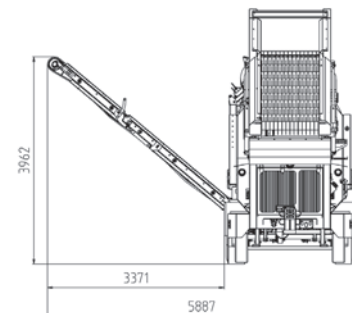
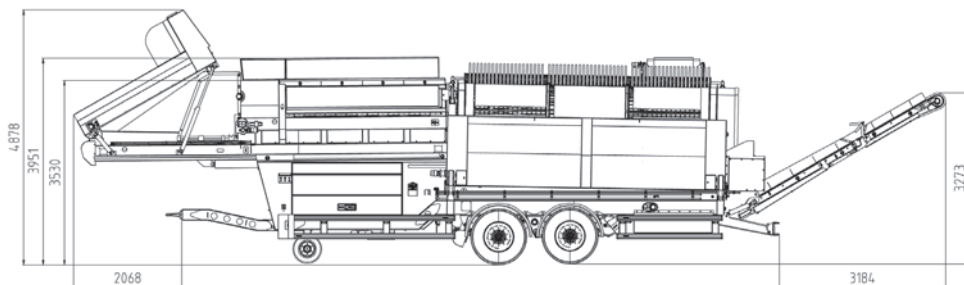
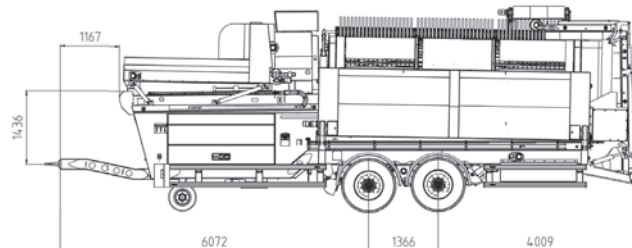

TECHNICAL DATA

TTS 520 / TTS 520-3

	TTS 520	TTS 520-3
Main Data		
Concept	Drum screen machine	Drum screen machine
Dead Weight	14,000 kg	17,500 kg
Maximum Gross Vehicular Weight	18,000 kg	18,000 kg
Measurements Transport Position (lxbxh)	11.450 mm x 2.550 mm x 4.000 mm	
Chassis	tandem axle with suspension, approved for 80 km/h	
Tires	385 / 65 R 22,5	385 / 65 R 22,5
Electrical Installation	24V	24V
Support Load	1,000 kg	

Drum

Inside Diameter	2,000 mm	
Length	5,150 mm	
Screen area in m ²	29 m ²	29 / 3 m ²
Output (performance)	30 - 100 m ³ /h	

Engine Data

Engine (Diesel)	John Deere 4045HF280
Performance	74 kW / 99 PS
Exhaust Emission Standard	Tier 3A
Tank Capacity	420l

In Feed Hopper

Loading Height	2,960 mm	3,500 mm
Loading Length, serial / extended	3,800 mm / 4,100 mm	4,000 mm / ---
In Feed Height	890 mm	730 mm
Bunker Capacity, serial / extended	4,5 m ³ / 5 m ³	4,5 m ³

Side Conveyor / Fine Fraction Conveyor Belt

Width	1,000 mm
Length, short/long	3,500 mm / 5,000 mm
Discharge Height, short/long	2,960 mm / 3,930 mm

Rear Conveyor / Oversize Conveyor

Width	1,000 mm
Length, short/long	3,500 mm / 5,000 mm
Discharge Height, short/long	2,500 mm / 3,280 mm

Subject to change without notice.

DUNGANNON

200 Coalisland Road
Dungannaon, Co Tyrone
BT71 4DR Northern Ireland

Tel: +44 (0) 28 87 718 500
Fax: +44 (0) 28 87 747 231

NEWTON

22 Whittier Street
Newton, NH, US, 03858

Tel: (603) 382-0556
Fax: (603) 382-0557

NIJVERDAL

Fuutweg 6
7442 CL Nijverdal
Netherlands

Tel: +31 548 37 49 06

LINZ

Actualstraße 32,
4053 Haid
Austria

Tel: +43 7229 780000

Dealer Stamp:

www.terex.com/environmental-equipment

Check out the TEE videos on YouTube: www.youtube.com/TerexEnviroEquip

Get the Terex Environmental Equipment product information instantly with
the Terex Environmental Equipment App from the Apple iStore



October 2015. The material in this document is for information only and is subject to change without notice. TEE assumes no liability resulting from errors or omissions in this document, or from the use of the information contained herein. Due to continual product development we reserve the right to change specifications without notice. Any product performance figures given in this brochure are for guidance purposes only. This information does not constitute an expressed or implied warranty or guarantee, but shows text examples provided. These results will vary depending on product settings, screen media and sizes, feed source and types of material being processed. Photographs are for illustrative purposes only. Some or all of the machines in the illustrations may be fitted with optional extra. Products and services listed may be trademarks, service marks or trade names of Terex Corporation and/or its subsidiaries in the USA and other countries. All rights reserved. Terex is a registered trademark of Terex Corporation in the USA and many other countries © 2014 Terex Corporation.